



The Culligan Smart Controller for Portable Exchange Deionization Systems and the Culligan Smart Monitor



Reduce risks in water related processes while reducing operating costs

The Culligan Smart Controller for PEDI systems and the Culligan Smart Monitor provides advanced control and monitoring for a wide variety of water treatment equipment. It can be used to monitor and control softeners, filters, ultra-filters, reverse osmosis and PEDI systems made by Culligan and most other manufacturers. With the Culligan Smart Controller / Monitor, which is comprised of multiple sensors and communications capabilities, customers can monitor their water treatment equipment performance and maintenance needs at a single site or across multiple ones 24/7. This helps companies to operate at improved efficiency, reduce potential production delays and decrease overall operating costs.



Pre-Treatment Solutions



Membrane Solutions



Deionization Solutions



Storage Solutions



Distribution Solutions

Culligan Smart Controller for PEDI systems

Application: PEDI Bank Switcher

In this mode the Culligan Smart Controller can be used to switch between two banks of DI tanks.

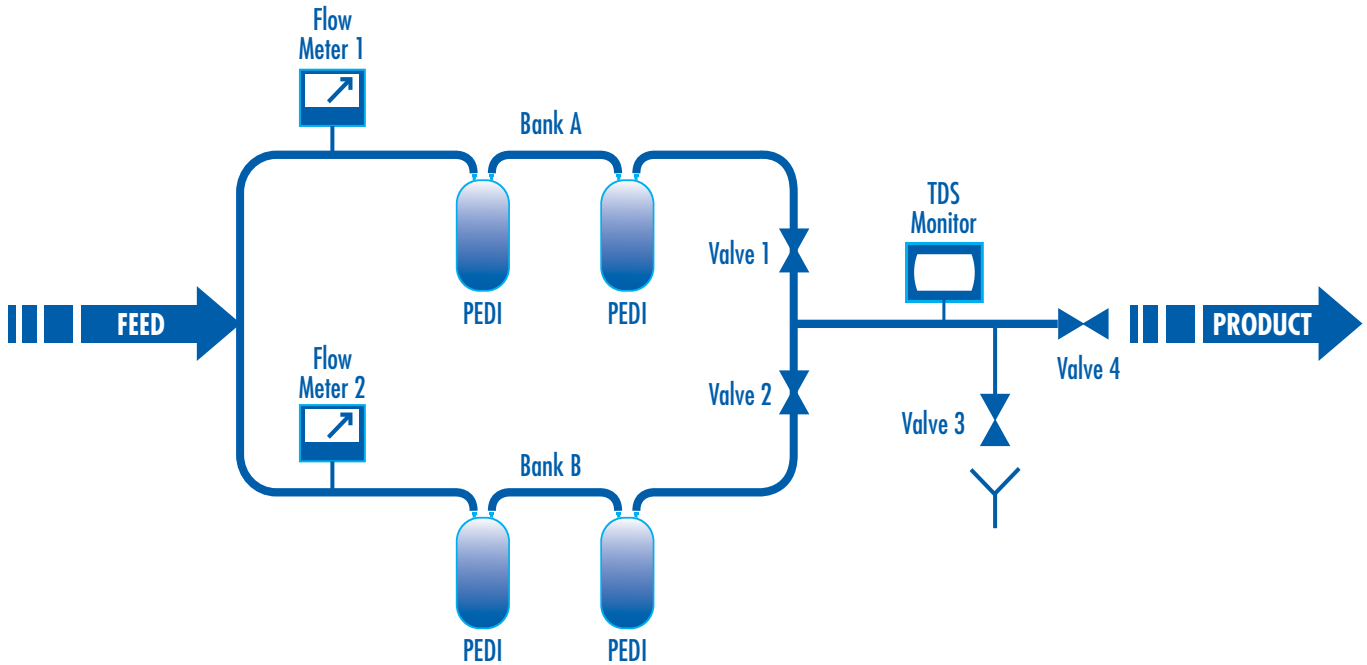

How it works:

At first deionized water from bank "A" is sent to drain until a specific quality is met. This is called a quality rinse. Once the water quality requirement is met then high quality deionized water flows to service. The system continues to monitor water quality and provides deionized water from bank "A" until bank "A" is no longer able to produce the specified water quality. At this point it switches to bank "B" and repeats the same process with bank "B". The system monitors the total gallons of water and the average daily gallons through each bank. It also allows both banks to be set with a capacity and the system counts down from that capacity until it reaches 0. At this point, the system calls in, to indicate that the total capacity has been exhausted. However, as long as water of sufficient quality is produced by the system, deionized water continues to be supplied to service.

Culligan Smart Monitor

Application: Culligan Smart Monitor for PEDI, Softener or Filter

In this mode, the Culligan Smart Monitor can supervise either one PEDI tank or up to two softener or filter tanks.

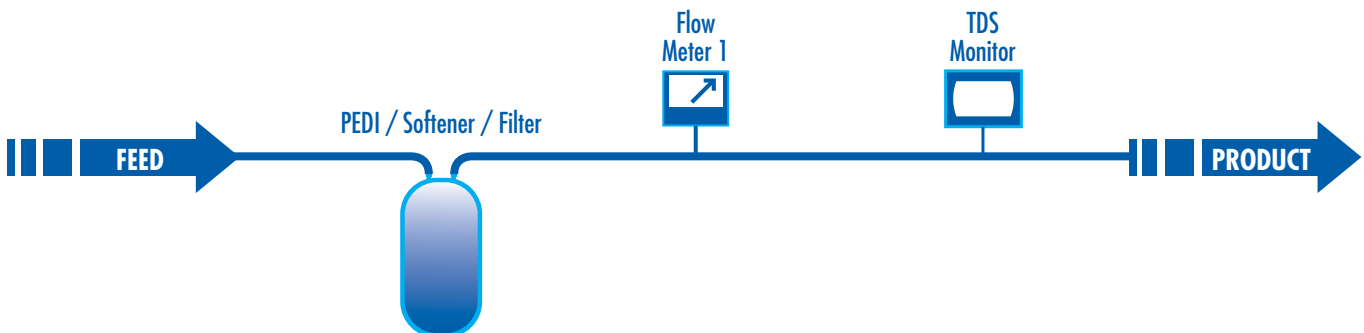

How it works:

The tanks can each be programmed with an initial capacity. With the flow meter(s) the system monitors the remaining capacity in each tank, keeping track of average daily gallons used, and remaining capacity. When the remaining capacity reaches zero, an alarm condition is generated. One TDS probe can be used to determine if the product TDS is exceeding its programmed limit. Differential pressure switches can also be used to trigger an alarm. Furthermore, up to two pressure transducers can be programmed with upper and lower limits. If the upper or lower limits are exceeded, the monitor will trigger an alarm. External dry contact

Application: Culligan Smart Monitor for RO

In this mode the Culligan Smart Monitor supervises a RO system.

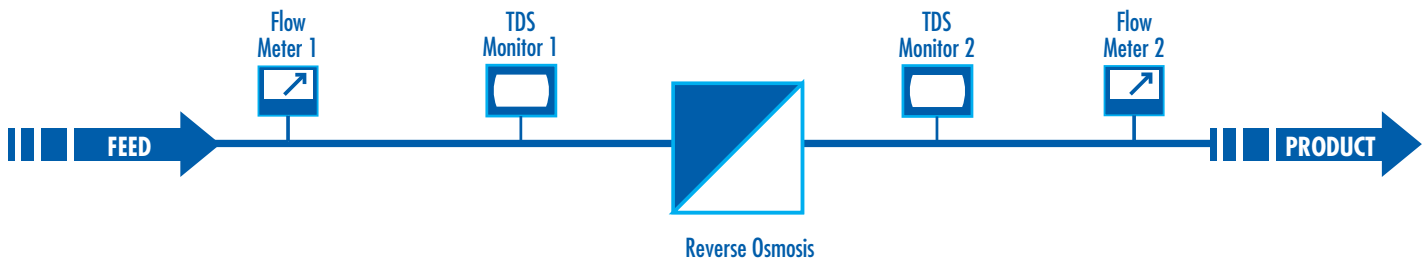

How it Works:

The Culligan Smart Monitor can be connected to flow meters, water quality (TDS) probe, temperature probes, and pressure transducers monitoring the performance of an RO system. With the pressure transducers on membrane feed and waste lines, product flow meter and a temperature probe, the Smart Monitor can calculate normalized flow through the membranes. With the flow meters the Smart monitor can calculate % recovery and % rejection. Furthermore, limits can be set on %recovery, % rejection, product TDS, water temperature and pressure so that the system generates an appropriate error message if a limit is exceeded. Many RO controllers have a dry contact alarm output. A dry contact output can be connected to one of the switch inputs on the Culligan Smart Monitor.

A Global Monitoring Solution with Customized Local Service

- 1 Equipment in the field
- 2 Data travels worldwide via phone, cellular, satellite and Internet
- 3 All data stored and backed-up for later retrieval
- 4 Customer and Service Techs alerted

Single or multiple pieces of equipment in the field.

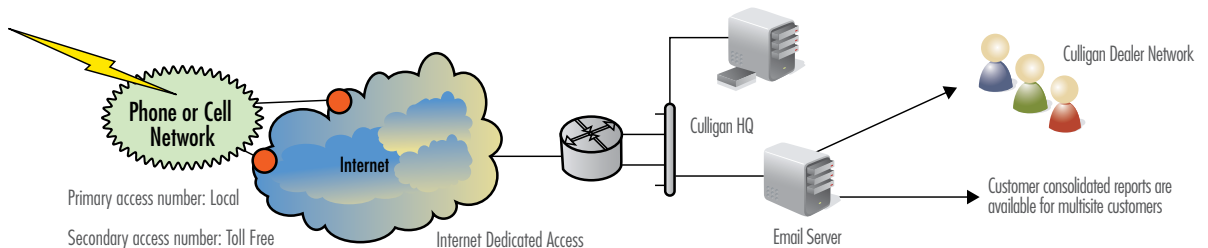

Exclusive Culligan Smart Controller for PEDI and Smart Monitor Features Include:

- **Historical Operating Data**
Starting at the time of installation, system operating data is stored and can be accessed to monitor trends over time.
- **Alarm Recognitions**
The Culligan Smart Controller allows you to monitor and set lower and upper limits on a number of system parameters.
- **SCADA / Control Room PLC Interface**
The Culligan Smart Controller can operate as a remote terminal unit (RTU) and can be monitored directly by the Customer's control room SCADA system. Connections are available for RS232, RS485, USB and Modbus communication networks.
- **Telemetry Options**
With telemetry options, you can connect your Matrix water treatment system via landline or cellular phone to Culligan.

Benefits of using the Culligan Smart Controller for PEDI and the Culligan Smart Monitor

- **Reduced labor costs**
The Culligan Smart Controller for PEDI systems automatically switches banks eliminating the need for manual control, which helps reduce labor costs.
- **Help customer quickly respond to system variations and promote consistent water quality**
The alarm recognition feature provides an alarm output if specific limits for system parameters are exceeded, allowing the customer to respond quickly to system variations and promote consistent water quality.
- **Predictability of maintenance**
The historical operating data feature, allows customers to monitor trends over time and predict maintenance schedules.
- **Continuous monitoring and control 24/7 with local service**
The telemetry feature and the Culligan dealer service network allow us to monitor a water treatment system centrally and service the system locally.

Finally, an end-to-end solution from a single source.



Place your industrial and commercial water treatment needs in the hands of a global leader.

For over 70 years, Culligan has made better water. Our global network, comprised of 800+ dealers and international licensees in over 90 countries, is dedicated to addressing your water-related problems. As a worldwide leader in water treatment, our sales representatives and service technicians are familiar with the local water conditions in your area. Being global and local position us to deliver customized solutions to commercial and industrial water issues that affect your business and your bottom line.

www.culliganmatrixsolutions.com • 866-787-4293

RR Donnelley # 47201 Print 12/10 ©2010 Culligan International Company.

All trademarks used herein are registered trademarks of Culligan International Company.
Products manufactured or marketed by Culligan and its affiliates are protected by patents issued or pending in the United States and other countries.
Culligan reserves the right to change the specifications referred to in this literature at any time, without prior notice.



Printed on
recycled paper